

PRODUCT SPECIFICATION

浩然显示

PRODUCT : 3.5" HVGA TFT**MODEL NO. :** HT035K1HV50C**VERSION:** V1.1**DATE :** 2014/08/07**CUSTOMER:** _____**SPECIFICATION****FOR****HT035K1HV50C****V 1.0**

Customer Confirmation column

Approved by: _____ Dept.: _____ Data: _____

Please return one of the copies of the specifications with your signature to us within two weeks after you receive this document. If it is not returned, we will assume that you agree to the entire contents of this specification document.

HaoRan Display Confirmation column

Design: _____ **Check:** _____ **Approval:** _____

Shenzhen HaoRan Display Co., Ltd

PRODUCT SPECIFICATION**CONTENTS**

No.	ITEM	PAGE
---	COVER	1
---	CONTENTS	2
---	RECORD OF REVISIONS	3
1.0	COMPOSITION	4
2.0	MECHANICAL SPECIFICATIONS	4
3.0	ELECTRICAL SPECIFICATIONS	5
4.0	DIMENSIONAL DIAGRAM	6
5.0	TERMINAL FUNCTIONS	7
6.0	BLOCK DIAGRAM	9
7.0	OPTICAL CHARACTERISTICS	10
8.0	RELIABILITY	14
9.0	STANDARDS OF INSPECTION ITEMS	15
10.0	PRECAUTIONS	16
11.0	FINAL REMARKS	17

PRODUCT SPECIFICATION

RECORDE OF REVISIONS

VERSION NO.	REVISION DETA	PAGE	DESCRIPTION
1.0	2014/08/07	17	NEW RELEASED

PRODUCT SPECIFICATION

1.0 COMPOSITION

Display type:	[320(RGB) × 480 Dots, TFT LCD Module]
View Direction:	[12 O'clock]
Backlight:	[LED B/L White]
Driver IC:	[ILI9488]
Touch Panel:	[G+G Capacitive]
Driver IC For CTP:	[FT6206]
Operating temperature:	[-20~+70°C]
Storage temperature:	[-30~+80°C]

2.0 MECHANICAL SPECIFICATIONS

ITEM	STANDARD VALUES	UNITS
LCD type	3.5" TFT	
Pixel arrangement	320(RGB)×480	pixels
Module size	59.00×88.33×3.55 MAX.	mm
Active area	48.96×73.44	mm
Pixel Pitch	153×153	um
Viewing direction	12 O'clock	

PRODUCT SPECIFICATION

3.0 ELECTRICAL SPECIFICATIONS

3.1 TFT-LCD Module Characteristics

ITEM	SYMBOL	CONDITIONS	MIN	TYP	MAX	UNITS
Power-supply Voltage	VCC	Ta = 25 °C	2.5	3.3	3.6	V
DC/DC Super Voltage	IOVCC	Ta = 25 °C	1.8	3.3	3.6	
Input Voltage	VIH	H level	$0.8 \times VCC$	—	VCC	
	VIL	L level	GND	—	$0.2 \times VCC$	
Supply Current For Logic	IDD	VCC= 3.3V	—	4	—	mA
LCD Frame Frequency	FLM		—	60	—	Hz

3.2 Backlight Characteristics

ITEM	SYMBOL	CONDITIONS	MIN	TYP	MAX	UNITS
Forward voltage	VF	IF=20mA	—	3.2	—	V
Uniformity	AVG		80	85	—	%
Luminance	Lv		4500	4800	—	Cd/m2

PRODUCT SPECIFICATION

5.0 TERMINAL FUNCTIONS FOR LCD PANEL

FPC connector is used for electronics interface. The recommended model is FH19SC-50S-0.5SH (05) manufactured by HIROSE.

Pin	Definition	Description
1	GND	Ground
2	IOVCC	Power(1.8~2.8V)
3	IOVCC	Power(1.8~2.8V)
4	VCI	Power(2.8V)
5	VCI	Power(2.8V)
6	IM0	Select Interface mode signal.
7	IM1	
8	IM2	
9	RESET	Hardware Reset
10	VSYNC	Frame synchronizing signal for DPI I/F mode. If not use, please connect to IOVCC.
11	HSYNC	Frame synchronizing signal for DPI I/F mode. If not use, please connect to IOVCC.
12	PCLK	Pixel clock signal for DPI I/F mode. If not use, please connect to VSSD.
13	DE	A DATA ENABLE signal for DPI I/F mode. If not use, please connect to VSSD.
14~31	DB17~DB0	When Operates in MIPI DBI interface mode, it is used liked an 18-bit bi-directional data bus. 8-bit bus: use DB7-DB0 9-bit bus: use DB8-DB0 1 6-bit bus: use DB15-DB0 1 8-bit bus: use DB17-DB0 When Operation in MIPI DPI interface mode, it is an 18-bit bus RGB data bus. 6-bit bus: use DB5-DB0 16-bit bus: use DB15-DB0 18-bit bus: use DB17-DB0 If not used, please connect to VSSD.
32	GND	Ground

PRODUCT SPECIFICATION

33	DOUT	Serial data output pin in serial bus system interface. If not used, please open this pin.
34	DINI_SDA	Serial data input pin or input/output pin in serial bus system interface. The data is inputted on the rising edge of the SCL signal. If not used, please connect to VSSD.
35	/RD	Read signal
36	/WR	Write signal
37	RS	Register selection signal
38	/CS	Chip selection signal
39	XR	Tuch panel signal
40	YD	Tuch panel signal
41	XL	Tuch panel signal
42	YU	Tuch panel signal
43	LEDA	LED Anode
44~49	LEDK1~LEDK6	LED Kathode
50	GND	Ground

3.1 Pin Description For Capacitive Touch Panel

FPC connector is used for electronics interface. The recommended model is FH19SC-6S-0.5SH (05) manufactured by HIROSE.

No.	Symbol	Function
1	GND	Power ground
2	SCL	Serial clock For CTP
3	SDA	Serial data input/output For CTP
4	INT	Interrupt signal For CTP
5	RESET	Reset input signal For CTP
6	VCC	Power voltage For CTP

PRODUCT SPECIFICATION

6.0 BLOCK DIAGRAM

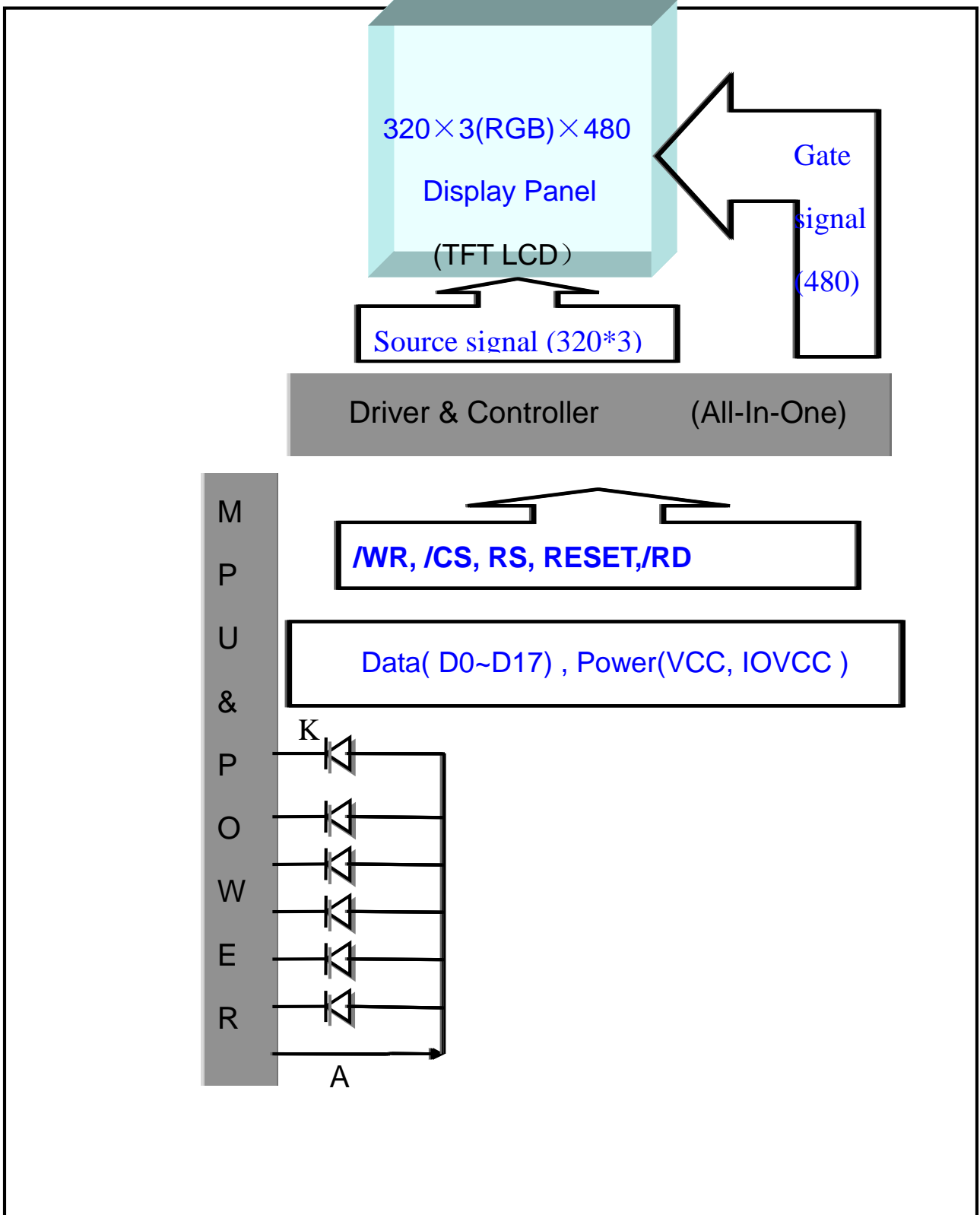

PRODUCT SPECIFICATION

7.0 OPTICAL CHARACTERISTICS

7.1 Measurement Parameter

ITEM		SYMBOL		CONDITIONS	MIN	TYP	MAX	UNITS
Viewing Angle	Hor	θ_L	C/R \geq 10 B/L On	-	60	-	Deg	
		θ_R		-	60	-		
	Her	ϕ_H		-	70	-		
		ϕ_L		-	50	-		
Luminance Of White(Center Point)		Y_L		-	250	-	cd/m ²	
Contrast Ratio		C/R		150	350	-	-	
Response Time	Rising: T_R	T_{R+T_F}		-	30	50	ms	
	Falling: T_F							
Color Chromaticity	White	x	$\phi = 0$ $\theta = 0^\circ$ Normal Viewing Angle B/L On	0.278	0.308	0.338	—	
		y		0.316	0.346	0.376		
	Red	x		0.603	0.633	0.663		
		y		0.299	0.329	0.359		
	Green	x		0.264	0.294	0.324		
		y		0.546	0.576	0.606		
	Blue	x		0.103	0.133	0.163		
		y		0.092	0.122	0.152		

PRODUCT SPECIFICATION

7.2 Measurement System

Notes:

1. Definition of Contrast Ratio (CR):

The contrast ratio can be calculated by the following expression.

$$\text{Contrast Ratio (CR)} = L_{63} / L_0$$

L63: Luminance of gray level 63

L 0: Luminance of gray level 0

$$\text{CR} = \text{CR} (10)$$

CR (X) is corresponding to the Contrast Ratio of the point X at Figure 4

2. Surface luminance is the center point across the LCD surface 500mm from the surface with all pixels displaying white. For more information see FIG 1.
3. Response time is the time required for the display to transition from white to black (Rising Time, T_r) and from black to white (Falling Time, T_f). For additional information see FIG 2.
4. Viewing angle is the angle at which the contrast ratio is greater than 10. The angles are determined for the horizontal or x axis and the vertical or y axis with respect to the z axis which is normal to the LCD surface. For more information see FIG 3.

FIG. 1 Measurement Set-Up:

The LCD module should be stabilized at a given temperature for 20 minutes to avoid abrupt temperature change during measuring. In order to stabilize the luminance, the measurement should be executed after lighting Backlight for 20 minutes in a windless room.

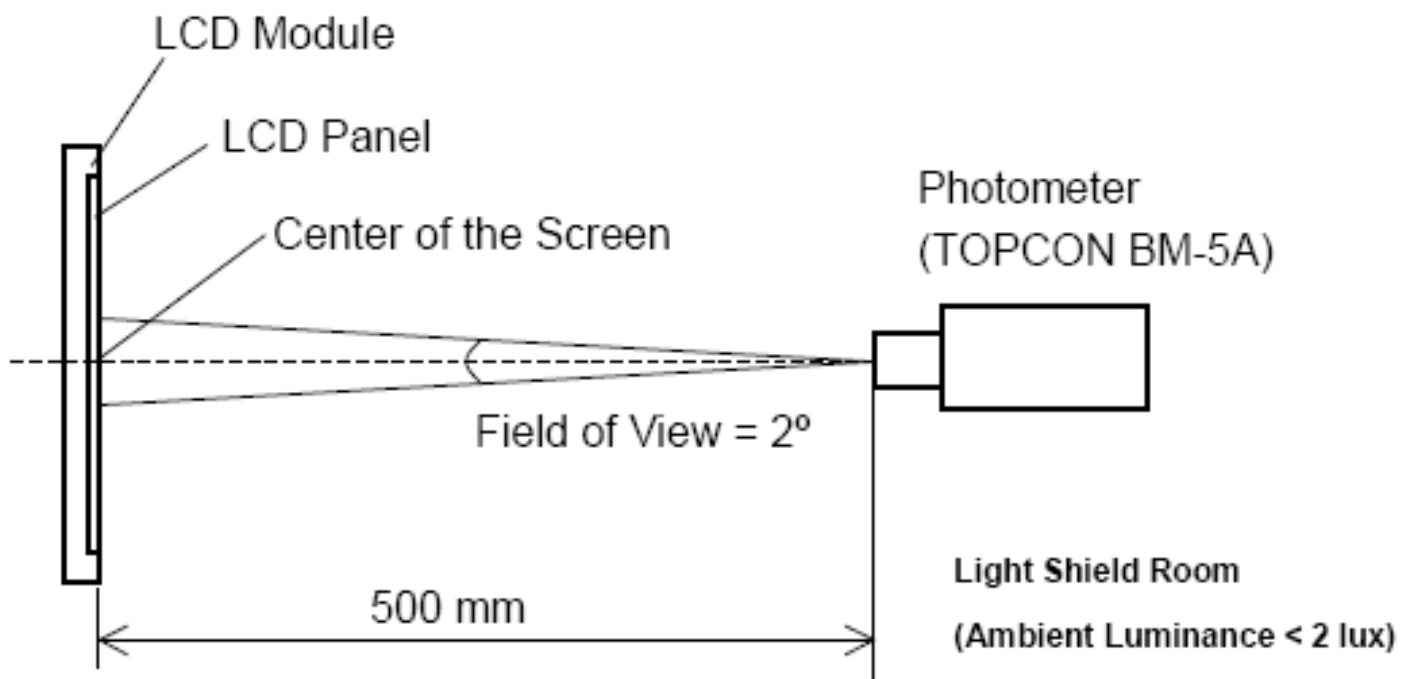

PRODUCT SPECIFICATION

FIG. 2 The definition of Response Time

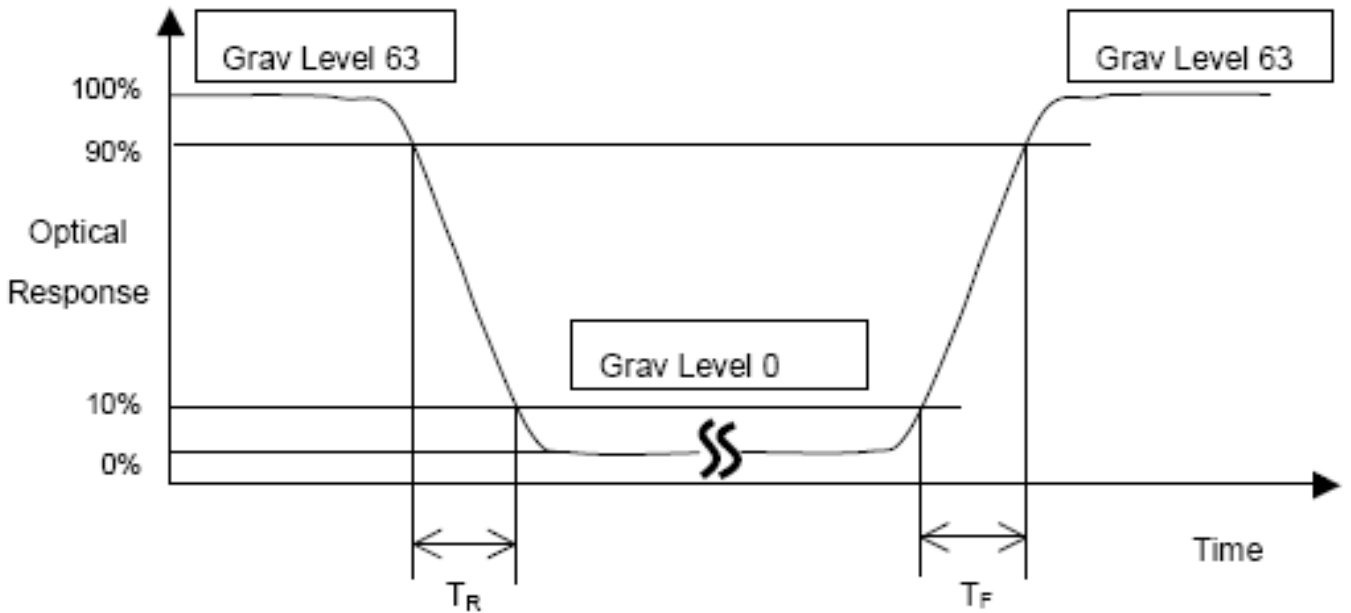
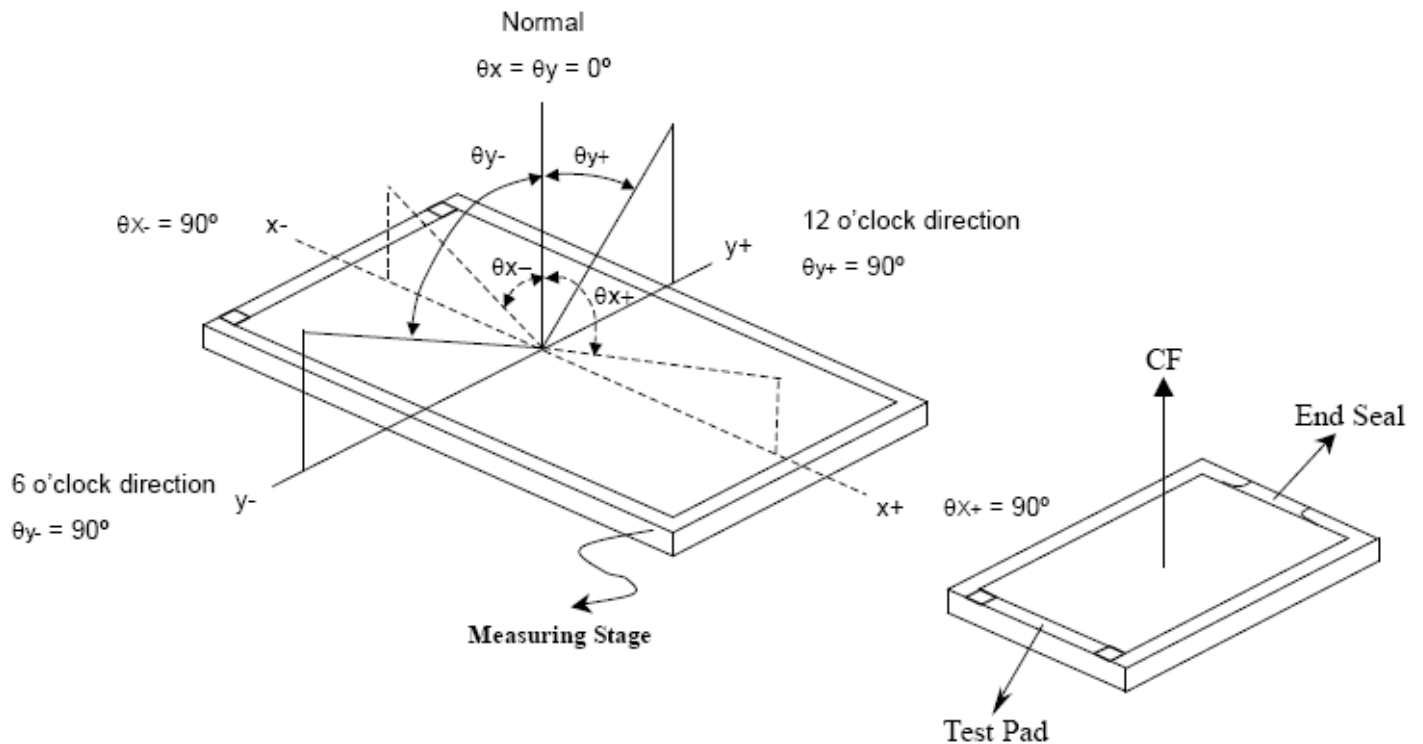

FIG. 3 The definition of Viewing Angle

Use Fig. 1 (Test Procedure) under Measurement System to measure the contrast from the measuring direction specified by the conditions as the following figure.



PRODUCT SPECIFICATION

FIG.4

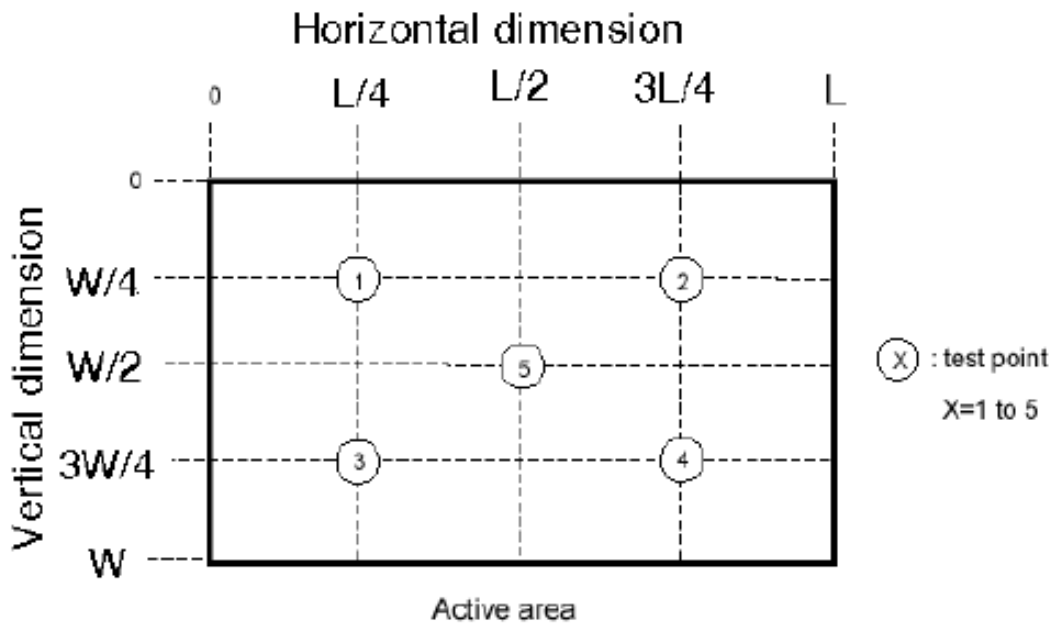

8.0 RELIABILITY

ITEM	CONDITIONS	CRITERIA
High temperature operation	70°C±2°C for 120 hours	<ul style="list-style-type: none"> ◆ No defect in cosmetic and operational functions. ◆ Total current consumption below double of initial value.
Low temperature operation	-20 °C±2°C for 120 hours	
High humidity storage	50 °C±5°C, 90 % RH for 120 hours	
High temperature storage	80 °C±2°C for 200 hours	
Low temperature storage	-30 °C±2°C for 200 hours	
Temperature cycling	-20 °C±2°C (30 min) ↓↑ 25 °C±2°C (5 min) ↓↑ 70 °C±2°C (30 min) Cycles: 10	

PRODUCT SPECIFICATION

Vibration	Frequency: 10Hz ~55Hz~10Hz Amplitude: 1.5mm Each Direction (X, Y, Z): 3hours (Packing condition)	
Hitting durability	250,000 times min. (Tip R12.5) 250g, 60 次/1min	
Pen sliding durability	100,000 times min. (Tip R0.8mm) 250g, 60mm/s	

Note:

- 1) The test samples should be applied to only one test item.
- 2) Sample size for each test item is 5~10pcs.
- 3) For Damp Proof Test, pure water(Resistance>1MΩ) should be used.
- 4) In case of malfunction defect caused by ESD damage, if it would be recovered to normal state after resetting, it would be judged as a good part.
- 5) EL evaluation should be excepted from reliability test with humidity and temperature: Some defects such as black spot/blemish can happen by natural chemical reaction with humidity and fluorescence EL has.
- 6) After the reliability test, the test samples should be inspected after 2 hours at least.
- 7) Functional test is OK. Missing segment, shorts, unclear segment, non display, display abnormally, liquid crystal leak are not allowed.
- 8) After testing, the current Idd should be within initial value $\pm 20\%$.

No low temperature bubbles ,end seal loose and fall, frame rainbow, ACF bubble growing are allowable in the appearance test.

9.0 STANDARDS OF INSPECTION ITEMS

NO	Item	Criterion	Level
01	Product condition	1.1 The part number is inconsistent with work order of product	Major
		1.2 Mixed product types	Major
		1.3 assembled in inverse direction	Major
02	quantity	The quantity is inconsistent with work order of product	Major
03	Outline dimension	product dimension and structure must conform to structure diagram	Major
04	electrical test	4.1 Missing line character and icon.	Major
		4.2 No function or no display	Major
		4.3 Display malfunction	Major
		4.4 LCD viewing angle defect.	Major

PRODUCT SPECIFICATION

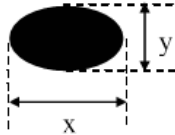
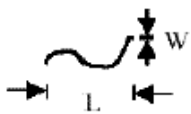
05	Black or white dot、scratch、contamination Round type $\Phi=(X+Y)/2$ 	Round type: <table border="1" style="width: 100%; border-collapse: collapse;"> <thead> <tr> <th rowspan="2">Dimension (diameter : Φ)</th> <th colspan="2">Acceptance (Q'ty)</th> </tr> <tr> <th>A area</th> <th>B area</th> </tr> </thead> <tbody> <tr> <td>$\Phi \leq 0.15\text{mm}$</td> <td>Don't count</td> <td>Don't count</td> </tr> <tr> <td>$0.15\text{mm} < \Phi \leq 0.20\text{mm}$</td> <td>2</td> <td>Don't count</td> </tr> <tr> <td>$\Phi > 0.25\text{mm}$</td> <td>0</td> <td>Don't count</td> </tr> </tbody> </table>	Dimension (diameter : Φ)	Acceptance (Q'ty)		A area	B area	$\Phi \leq 0.15\text{mm}$	Don't count	Don't count	$0.15\text{mm} < \Phi \leq 0.20\text{mm}$	2	Don't count	$\Phi > 0.25\text{mm}$	0	Don't count	Minor								
Dimension (diameter : Φ)	Acceptance (Q'ty)																								
	A area	B area																							
$\Phi \leq 0.15\text{mm}$	Don't count	Don't count																							
$0.15\text{mm} < \Phi \leq 0.20\text{mm}$	2	Don't count																							
$\Phi > 0.25\text{mm}$	0	Don't count																							
06	Line type 	Line type: <table border="1" style="width: 100%; border-collapse: collapse;"> <thead> <tr> <th rowspan="2">Length</th> <th rowspan="2">Width</th> <th colspan="2">Acceptance (Q'ty)</th> </tr> <tr> <th>A area</th> <th>B area</th> </tr> </thead> <tbody> <tr> <td>---</td> <td>$W \leq 0.03\text{mm}$</td> <td>Don't count</td> <td>Don't count</td> </tr> <tr> <td>$L \leq 2.5\text{mm}$</td> <td>$0.03\text{mm} < W \leq 0.05\text{mm}$</td> <td>2</td> <td>Don't count</td> </tr> <tr> <td>$L \leq 3.0\text{mm}$</td> <td>$0.03\text{mm} < W \leq 0.05\text{mm}$</td> <td>1</td> <td>Don't count</td> </tr> <tr> <td>---</td> <td>$W > 0.05\text{mm}$</td> <td colspan="2" style="text-align: center;">As round type</td> </tr> </tbody> </table>	Length	Width	Acceptance (Q'ty)		A area	B area	---	$W \leq 0.03\text{mm}$	Don't count	Don't count	$L \leq 2.5\text{mm}$	$0.03\text{mm} < W \leq 0.05\text{mm}$	2	Don't count	$L \leq 3.0\text{mm}$	$0.03\text{mm} < W \leq 0.05\text{mm}$	1	Don't count	---	$W > 0.05\text{mm}$	As round type		Minor
Length	Width	Acceptance (Q'ty)																							
		A area	B area																						
---	$W \leq 0.03\text{mm}$	Don't count	Don't count																						
$L \leq 2.5\text{mm}$	$0.03\text{mm} < W \leq 0.05\text{mm}$	2	Don't count																						
$L \leq 3.0\text{mm}$	$0.03\text{mm} < W \leq 0.05\text{mm}$	1	Don't count																						
---	$W > 0.05\text{mm}$	As round type																							
07	Touch Panel	7.1 No function. 7.2 The circuitry type must match type in specification sheet. 7.3 Appearance inspection as the glass.	Major Major Major																						
08	Backlight elements	8.1 Light leaks to induce deficiency lightness . 8.2 Backlight doesn't light or color is wrong. 8.3 Illumination source flickers when lit. 8.4 he contamination of backlight as NO.05.	Major Major Major Minor																						
09	Flexible Printed Circuit	9.1 FPC PIN type is inconsistent with specification sheet. 9.2 Short circuits in components on FPC. 9.3 A part of circuits in components on FPC is missing or wrong 9.4 The crack is in circuits of FPC.	Major Major Major Major																						

10.0 PRECAUTIONS

10.1 Static charge

Since this LCD module contains CMOS LSIs that are sensitive to static charge, care must be taken when handling it.

10.2 Power on sequence

1. Input signals should not be applied to the LCD module before the logic system voltage has reached the specified voltage. If the above sequence is not kept the LCD module might be permanently damaged.
2. When connecting the power supply, connect the LCD bias voltage *after* connecting the logic system voltage.
3. When disconnecting the power supply, disconnect the logic system voltage *after* the LCD bias voltage.
4. It is recommended to connect a serial resistor or fuse to the LCD bias power supply of the system, as a current limiter. The value of the resistor depends on the kind of LCD used, but is typically 50 ~ 100 Ω .

PRODUCT SPECIFICATION

10.3 Operation

1. It is essential to drive the LCD within the specified voltage limits, since a higher driving voltage than allowed causes a shorter LCD lifetime. Under these circumstances, electrochemical reactions will result in undesirable deterioration of the LCD.
2. The response time of the LC fluid is considerably longer at low temperatures than in the normal operating temperature range. On the other hand, the LCD will show a dark blue color at high temperatures. Those phenomena do not indicate a malfunction or defect of the LCD. Back at normal temperatures, the LCD will return to its original behavior.
3. If the display area is pressed hard during operation, some abnormal display patterns might appear. However, the display will resume normal operation after turning the module off and on.
4. Moisture on the terminals could cause an electrochemical reaction resulting in an open terminal connection. If the environmental temperature is higher than 40°C, it is required that the relative humidity is 50% or less.

10.4 Packaging

1. Do not leave the product in a place of high humidity for a long period. For storage in a location where the temperature is 35°C or higher, special care to protect the product from high humidity is required. A combination of high temperature and high humidity may cause polarization degradation and damage as well. Please keep the temperature and humidity within the specified range for storing.
2. Since LCD panels tend to be easily damaged, they should be handled with full care. Avoid any contact with materials that have a hardness of more than 2H.
3. Adhesives used for adhering upper/lower polarizers and aluminum plates are made of organic substances that will deteriorate by chemical reactions with for example chemicals such as acetone, toluene, ethanol, and isopropylalcohol. Please prevent the use of these chemicals and contact us when it is necessary for you to use other chemicals.
4. Immediately wipe off saliva or water drops from the display area with an absorbent cotton cloth, without scrubbing it. If adhered for a long period, such particles might cause deformation or faded color.
5. Moisture deposited on the display surface and contact terminals due to low temperatures will be a cause for polarizer damage, stains, and dirt. Before use, such panels should be slowly warmed up to a temperature that is higher than room temperature.
6. Touching the display area and contact terminals with bare hands is harmful to polarizer and may lead to poor insulation at the terminals.
7. The glass is fragile and can be cracked or chipped easily by handling, in particular on near its edge. Please prevent sudden shocks or exposing the glass to other sorts of stress.

10.5 Long-term storage

For long-term storage the following methods are highly recommended:

1. Store the product in a polyethylene bag with a sealed opening to prevent fresh air entering from the outside. Placing it with a desiccant is not necessary.
2. Store the product in a dark place, with the temperature in the range from 0 °C to 35 °C.
3. Keep the sensitive polarizer surface of the LCD panels clear of any contact. We recommend using the container that

PRODUCT SPECIFICATION

was used by SPACE DISPLAY to deliver the products.

10.6 Cleaning of the product

To clean the product make sure to use absorbent cotton cloth or other soft material like chamois. Make sure to rub it gently, and do not use chemicals when cleaning.

11.0 FINAL REMARKS

1. The above specifications are the binding criteria for HaoRan Display's outgoing quality inspection.
2. The customer is kindly requested to inform HaoRan Display as soon as possible on any questions, remarks, and disagreements regarding these specifications.
3. HaoRan Display is not responsible for damage to its products due to neglect of the precautions as described in the previous chapter.